

Localization of the Gene for a Novel Autosomal Recessive Neurodegenerative Huntington-Like Disorder to 4p15.3

M. Kambouris,^{1,3} S. Bohlega,¹ A. Al-Tahan,² and B. F. Meyer¹

¹King Faisal Specialist Hospital & Research Center and ²King Saud University, Riyadh, Saudi Arabia; ³Yale University School of Medicine, New Haven, Connecticut

Summary

A consanguineous family affected by an autosomal recessive, progressive neurodegenerative Huntington-like disorder, was tested to rule out juvenile-onset Huntington disease (JHD). The disease manifests at ~3–4 years and is characterized by both pyramidal and extrapyramidal abnormalities, including chorea, dystonia, ataxia, gait instability, spasticity, seizures, mutism, and intellectual impairment. Brain magnetic resonance imaging (MRI) findings include progressive frontal cortical atrophy and bilateral caudate atrophy. Huntington CAG trinucleotide-repeat analyses ruled out JHD, since all affected individuals had repeat numbers within the normal range. The presence of only four recombinant events ($\theta = .2$) between the disease and the Huntington locus in 20 informative meioses suggested that the disease localized to chromosome 4. Linkage was initially achieved with marker D4S2366 at 4p15.3 (LOD 3.03). High-density mapping at the linked locus resulted in homozygosity for markers D4S431 and D4S394, which span a 3-cM region. A maximum LOD score of 4.71 in the homozygous interval was obtained. Heterozygosity at the distal D4S2366 and proximal D4S2983 markers defines the maximum localization interval (7 cM). Multiple brain-related expressed sequence tags (ESTs) with no known disease association exist in the linkage interval. Among the three known genes residing in the linked interval (*ACOX3*, *DRD5*, *QDPR*), the most likely candidate, *DRD5*, encoding the dopamine receptor D5, was excluded, since all five affected family members were heterozygous for an intragenic dinucleotide repeat. The inheritance pattern and unique localization to 4p15.3 are consistent with the identification of a novel, autosomal recessive, neurodegenerative Huntington-like disorder.

Introduction

A nuclear family with five members affected by an early onset (3–4 years), apparently autosomal recessive, neurodegenerative disorder resembling juvenile-onset Huntington disease (JHD [MIM 143100]) was referred for DNA testing to rule out JHD. JHD manifests between the first and fourth years of life (Farrer and Conneally 1985; van Dijk et al. 1986) and presents with an atypical Huntington clinical picture characterized by Parkinsonism, dystonia, seizures, and pyramidal abnormalities in association with progressive dementia (van Dijk et al. 1986). Phenocopies of HD have been described in the literature and have been grouped as a unique OMIM entry (Huntington-disease-like neurodegenerative disorder [MIM 603218]). In a cohort study of 1,022 individuals with Huntington-like features (Andrew et al. 1994), 12 patients did not show an expanded CAG repeat in the HD locus. In at least four cases, family studies excluded 4p16.3 (HD region) as the locus responsible for the phenotype. Mutations in the HD gene other than CAG expansion were not excluded for the remaining eight cases. However, in as many as seven of these cases, retrospective review of their clinical features identified characteristics not typical of HD. The investigators speculated that on rare occasions mutations in other, as-yet-undefined genes can present with a clinical phenotype very similar to that of HD. Xiang et al. (1998) investigated a family with a late-onset autosomal dominant (affected members were observed in three generations of the family) Huntington-like disorder without CAG-repeat expansion in the HD gene. The chromosome 4p region was excluded by linkage analysis. The disease gene was then mapped to chromosome 20p (LOD 3.01 for marker D20S482) in a 2.7-cM region between the markers D20S193 and D20S895.

The family referred for DNA testing consists of 12 individuals: parents who are healthy first cousins in the sixth decade of life, and five normal and five affected siblings. The disease is characterized by both pyramidal and extrapyramidal abnormalities, including chorea, dystonia, ataxia, gait instability, spasticity, seizures, mutism, and intellectual impairment. Despite the fact that

Received February 25, 1999; accepted for publication November 23, 1999; electronically published January 17, 2000.

Address for correspondence and reprints: Dr. Marios Kambouris, King Faisal Specialist Hospital & Research Center, P. O. Box 3354-MBC #03, Riyadh 11211, Saudi Arabia. E-mail: marios.kambouris@yale.edu

© 2000 by The American Society of Human Genetics. All rights reserved. 0002-9297/2000/6602-0012\$02.00

the mode of inheritance was clearly not autosomal dominant, Huntington CAG-repeat analysis was performed, because the phenotype of affected individuals resembled that of JHD. The disease was ruled out, since the Huntington locus CAG-repeat numbers were within the normal range for all affected individuals. Four affected and one normal sibling were homozygous for 18 CAG repeats, whereas one affected and four normal siblings were homozygous for 16 CAG repeats. Both parents were heterozygotes for 16 and 18 CAG repeats. The presence of only four recombinant events between the disease and the Huntington locus from 20 informative meioses ($\theta = .2$) in this family suggested that the disease may localize to chromosome 4. Thus, genotyping and linkage analyses were performed with microsatellite markers spanning the entire chromosome 4.

Subjects and Methods

Clinical Description

The nuclear family consists of 12 individuals: the parents (III:2 and III:3), who are healthy first cousins, and a sibship of ten (fig. 1). The order of birth of affected and unaffected siblings is: IV:10, IV:6, IV:7, IV:8, IV:3, IV:1, IV:2, IV:9, IV:4, and IV:5. Five of the children are healthy unaffected individuals, whereas the other five are affected by a neurodegenerative disorder as follows:

Individual IV:1.—A 21-year-old man. He had normal early developmental milestones with the exception of speech delay. At age 5 years, his speech became progressively incoherent, hand movements became clumsy, and his mobility was disturbed. He developed both rapid and slow involuntary movements of all limbs and trunk with deforming postures. By age 12 years, he became mute and wheel-chair bound and developed seizures and brief episodes of tonic-clonic movements of upper limbs with up-rolling of both eyes. At present, he is fully dependent. He is severely emaciated with diffused muscle contractures and absent or minimal voluntary movement of upper and lower extremities. He is alert, responding to verbal stimuli with localized full eye movements, but has limited head movement. His facial expression is poor but symmetric, and his muscle tone is increased. Brain computerized tomography (CT) and MRI studies showed generalized frontal cortical atrophy and bilateral caudate nuclei atrophy. Results of single-photon emission computerized tomography (SPECT) were normal.

Individuals IV:2 and IV:3.—A 19-year-old man and a 24-year-old woman. Both are bedridden and fully dependent. The clinical picture, including age at onset and course of disease, was similar to that of their aforementioned brother (individual IV:1).

Individual IV:4.—A 14-year-old girl. At age 4 years

she started showing mobility and speech disturbances. At age 8 years, she started having seizures and frequent brief episodes of generalized tonic movements, with flexion, crossing of both upper limbs, and extension of lower limbs. At present, she responds to simple commands with incoherent speech, excessive inappropriate shouting, and crying or laughter. She frequently displays choreoathetoid movements with variable limb and trunk abnormal posturing. She also exhibits rigidity with slow and awkward movements, and she is doubly incontinent.

Individual IV:5.—A 12-year-old girl with progressive deterioration of speech and mobility commencing at age 3–4 years. At age 9 years she became totally mute and incontinent, walked only with help, and needed assistance in feeding. There was early onset of abnormal choreiform movements. At present, she is emaciated and responds poorly to simple orders with poor facial expressions but full eye movements. She is able to move all limbs voluntarily, but only slowly, and with generalized rigidity. Apart from a wide-based gait, there is no evidence of cerebellar dysfunction.

Investigation

Investigations were performed to rule out various differential diagnoses. All patients had normal complete blood counts, blood film, renal, and liver-function tests, normal levels of serum and 24-h urine copper, serum ceruloplasmin, and normal findings from slit-lamp examinations. Electroencephalogram (EEG) results showed increased fast activity only. Nerve conduction and both visual and auditory evoked potentials were within normal limits. Screening for metabolic disorders and karyotypes gave normal findings.

Isolation and PCR Amplification of Genomic DNA

Peripheral blood samples were collected for genotyping from all 12 individuals in the nuclear family (parents, five affected individuals, and five normal individuals). Appropriate informed consent was obtained from the family for this study, and the study was approved by the King Faisal Specialist Hospital and Research Center's internal review board (Research Ethics Committee). All work was performed at the Research Center of King Faisal Hospital and Research Center. High-molecular-weight genomic DNA was extracted by use of standard salt-precipitation methods (Kendall et al. 1991). Genomic DNA (100 ng) was amplified in a 20- μ l reaction mixture containing 50 mM KCl, 10 mM Tris-HCl (pH 9.0), 1.5 mM MgCl₂, 0.1% Triton X-100, 0.25 mM each dNTP, 20 pM each primer, and 0.5 U *Taq* polymerase (Pharmacia). The amplification consisted of an initial denaturation of 5 min at 95°C followed by 40 cycles of denaturation at 94°C for 1 min, annealing for 1 min

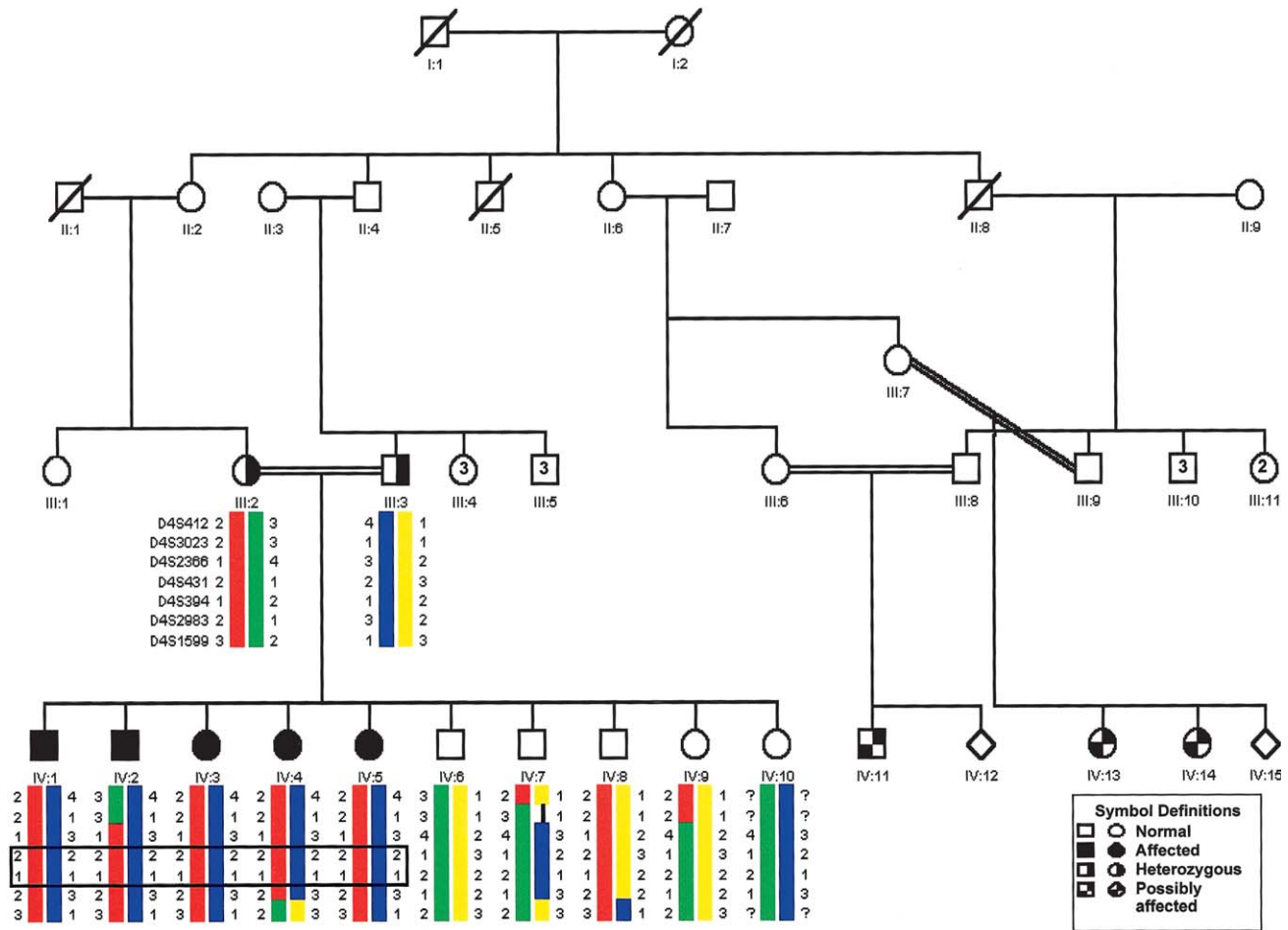

Figure 1 Pedigree of an inbred family affected with a novel neurodegenerative Huntington-like disorder. Double marriage lines indicate consanguineous marriages. Genotypes for seven DNA markers from chromosome 4p15.3 are shown. Regions of autozygosity are enclosed by a rectangle. The actual order of birth of affected and unaffected individuals is: IV:10, IV:6, IV:7, IV:8, IV:3, IV:1, IV:2, IV:9, IV:4, and IV:5.

(58°C for cycles 1–5, 54°C for cycles 6–10, 50°C for cycles 11–15, and, finally, 54°C for the remaining 25 cycles). Extension was at 72°C for 2 min in all cycles. Amplification was terminated after a single incubation at 72°C for 5 min.

Genotyping

A low-resolution (15–20 cM) scan of chromosome 4 was performed with nine fluorescently labeled primer sets from the Cooperative Human Linkage Center (CHLC) marker set for markers D4S2366, D4S2632, D4S2368, D4S1627, D4S3248, D4S2367, D4S2623, D4S1629, and D4S1652 as well as the Huntington CAG trinucleotide repeat (Bond and Hodes 1996). A high-resolution scan of the 4p15 region was performed with fluorescently labeled primers sets from the Généthon Chromosome 4 map for markers D4S412, D4S3023,

D4S2366, D4S431, D4S394, D4S2983, and D4S1599. Analysis was also performed for an intragenic dinucleotide repeat at the *DRD5* locus (Sherrington et al. 1993). Alleles were separated after amplification by electrophoresis in 1 × Tris-Borate-EDTA, 6% denaturing polyacrylamide gel on an ABI 373A automated sequencer, as recommended by the manufacturer. Data collection and analysis were done with GeneScan 672 software (PE Biosystems).

Statistical Analysis

Multipoint parametric linkage analysis was performed with GeneHunter (Kruglyak et al. 1996) and Map-Maker/Homoz (Kruglyak et al. 1995) linkage-analysis software. A 50%-penetrant autosomal recessive trait was assumed, and a disease-gene frequency of .0001 was used (appropriate for a very rare disease). Equal recom-

bination frequencies between males and females were assumed. Linkage analyses were done with allele frequencies estimated by parental data and with equal allele frequencies for all microsatellite markers. Identical results were obtained with the data sets.

Results

Analysis of the Huntington CAG trinucleotide repeat showed only two alleles (16 and 18 CAG repeats) in this family. Both parents were heterozygous (16/18 repeats). Four affected and one normal individual were homozygous for 18 repeats, whereas one affected and four normal siblings were homozygous for 16 repeats. JHD was thus excluded, because the Huntington CAG-repeat number was within the normal range (<27 repeats) for all affected individuals in this family.

A low-resolution scan of chromosome 4 was performed with 10 equally spaced (15–20 cM) fluorescently labeled microsatellite markers spanning the entire chromosome. All 12 individuals in the sibship were genotyped (fig. 1). Linkage analysis with GeneHunter resulted in a maximum LOD score of 3.03 with marker D4S2366 at *Hsa* 4p15.3 (table 1). High-density mapping at the linked locus was performed with seven fluorescently labeled microsatellite markers localizing at 4p15.3 (fig. 1). Multipoint parametric linkage analysis was performed by assuming a 50%-penetrant autosomal recessive trait and a disease gene frequency of .0001. The analysis resulted in a maximum LOD score of 3.03 (fig. 1*b*) for four perfectly linked markers (D4S2366, D4S431, D4S394, and D4S2983). Homozygosity was observed in all affected individuals for markers D4S431 and D4S394, which spanned a 3-cM region (fig. 1). A maximum LOD score of 4.71 in the homozygous interval was obtained by both GeneHunter and MapMaker/Homoz linkage analysis software (table 2, fig. 2*a*). Heterozygosity at the distal D4S2366 and proximal D4S2983 markers define a 7-cM interval within which the disease localizes (fig. 2*b*).

Analysis of an intragenic dinucleotide repeat in the *DRD5* gene (a likely candidate) showed four alleles (1, 2, 3, and 4) in this family. All affected individuals were heterozygotes (1/2). Paternal and maternal genotypes were 2/4 and 1/3, respectively. Alleles in the unaffected individuals were: 3/4 for IV:6, 2/3 for IV:7, 1/4 for IV:8, 3/4 for IV:9, and 2/3 for IV:10.

Discussion

This family is afflicted by an early-onset, progressive, neurodegenerative Huntington-like disorder, manifesting with both pyramidal and extrapyramidal abnormalities that include choreoathetosis, ataxia, dystonia,

Table 1

Multipoint Linkage Analysis for the Disease Locus and 10 Microsatellite Markers Spanning Chromosome 4 at 15–20 cM Intervals with GeneHunter

Marker	Distance (KcM)	Maximum LOD
HD	.00	–10,000
	3.57	.88
	7.13	1.78
	10.70	2.31
	14.27	2.71
D4S2366	17.83	3.03
	21.40	2.71
	24.97	2.31
	28.53	1.77
	32.10	.87
D4S2632	35.67	–10,000
	39.23	–1.13
	42.80	–.63
	46.37	–.64
	49.93	–1.16
D4S2368	53.50	–10,000
	57.07	–1.76
	60.63	–1.38
	64.20	–1.55
	67.77	–2.37
D4S1627	71.33	–10,000
	74.90	–4.72
	78.47	–3.91
	82.04	–3.73
	85.60	–4.12
D4S3248	89.17	–10,000
	92.74	–4.31
	96.30	–4.16
	99.87	–4.68
	103.44	–6.08
D4S2367	107.00	–10,000
	110.57	–4.04
	114.14	–3.01
	117.70	–2.79
	121.27	–3.32
D4S2623	124.84	–10,000
	128.40	–3.27
	131.97	–2.65
	135.54	–2.78
	139.10	–3.73
D4S1629	142.67	–10,000
	146.24	–5.04
	149.80	–4.19
	153.37	–4.21
	156.94	–5.04
D4S1652	160.50	–10,000

seizures, spasticity, mutism, and generalized intellectual impairment. All evidence indicates that inheritance for this disease is autosomal recessive. The disorder manifests in all affected individuals very early, at age 3–4 years, with a striking phenotype. Both male and female individuals are affected. The parents are first cousins, and both are healthy individuals late in the sixth decade

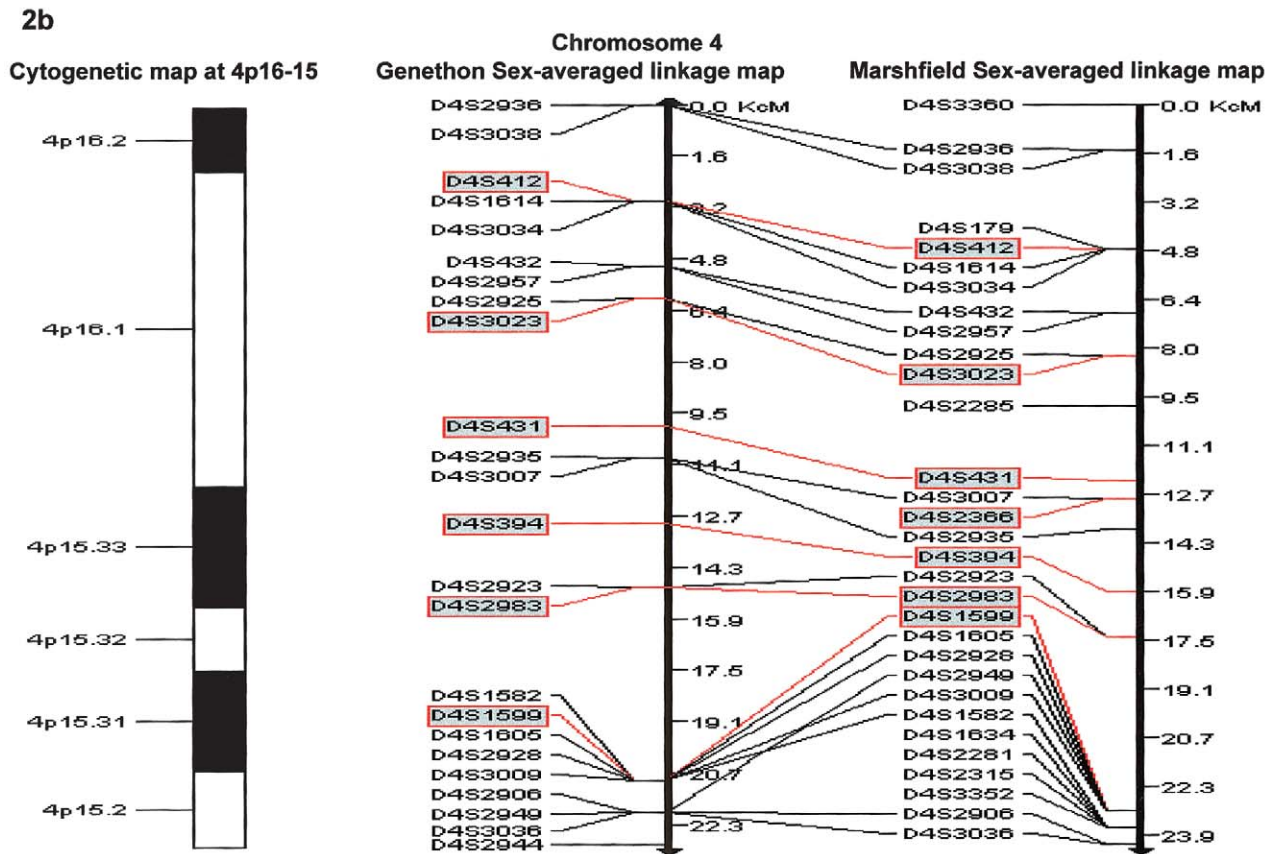
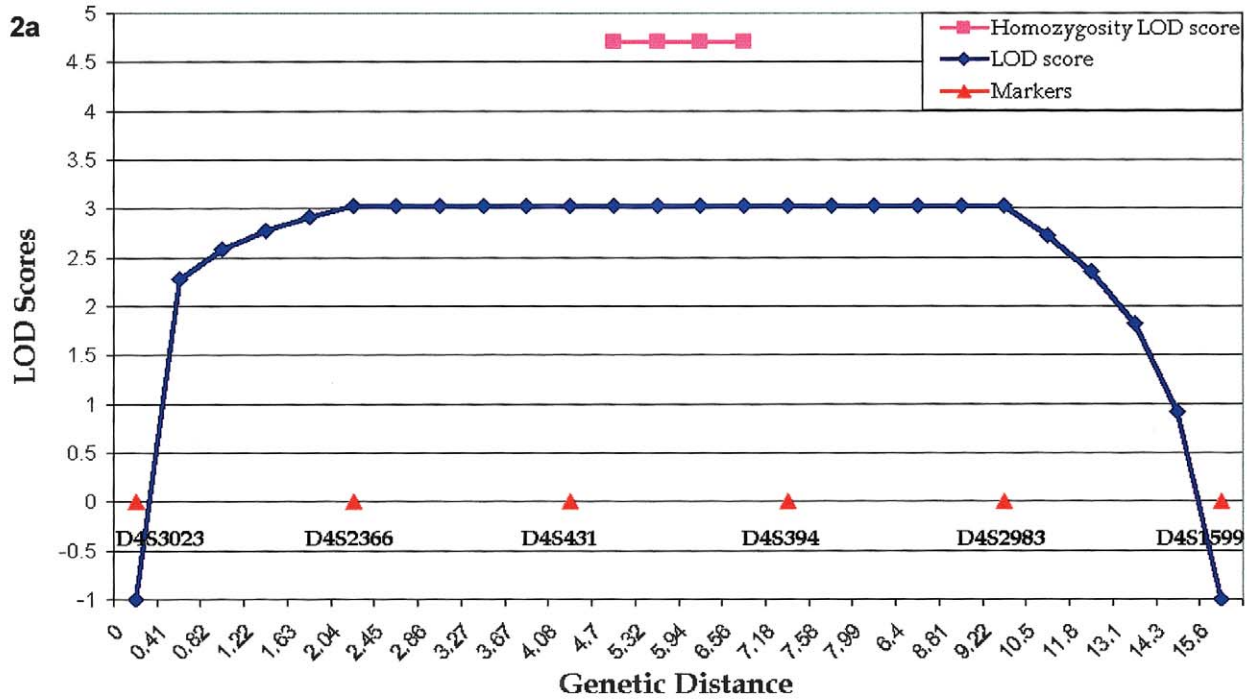

Figure 2 *a*, Multipoint linkage analyses for seven 4p15 markers with GeneHunter. Genetic distances and LOD scores are indicated. Marker order and distances are indicated. *b*, Chromosome 4 cytogenetic and linkage maps in the 4p16-15 region. Markers used for linkage analysis are highlighted.

of life. In addition, information exists that first cousins of the affected individuals (whose parents are also first cousins) are reportedly affected by a “debilitating neurological disorder,” although examination, evaluation, and genotyping of these individuals was not possible. Although the affected individuals in this family represent 50% of the sibship size—instead of the 25% expected for an autosomal recessive disorder—each pregnancy is an independent event, and the number of affected individuals in this sibship is possible.

The disease gene was localized to a 3-cM homozygous region at 4p15.3 with markers D4S431 and D4S394 (max LOD score 4.71). Heterozygosity at the distal D4S2366 and proximal D4S2983 markers define the maximum localization interval (7 cM). Despite the consanguineous marriage, it appears that four distinct chromosomal domains exist in the 4p region defining the linkage interval. This implies either that the disease allele-bearing chromosomes are relatively old in the family or that they do not all originate within this small group. The four distinct chromosomal domains at 4p could be accounted for by the presence of a “hot-spot” for recombination in the 4p region between markers D4S10 and D4S125 (spanning ~8 cM) immediately adjacent (distal) to the disease linkage interval (Bates et al. 1991). Two of the markers used for the high-density mapping (D4S412 and D4S3023) fall within the “hot-spot” and both show recombinant events in affected (IV:2) as well as in normal (IV:7 and IV:9) individuals. Thus, the presence of this recombination “hot-spot” is a possible explanation for both the limited region of homozygosity (confined between markers D4S431 and D4S394, a 3-cM interval) shared among the affected individuals and the appearance of four distinct chromosomal domains in the 4p region.

There are a number of known inherited disorders that map in the general 4p15-4pter region. These include: phenylketonuria II (*DHQR*), achondroplasia (*FGFR-3*), congenital stationary nightblindness 3 (*PDE6B*), mucopolysaccharidosis I (MPS I), Huntington disease (HD), Wolf-Hirschhorn syndrome (WHS), Ellis-van Creveld syndrome (EVC), diabetes mellitus and insipidus with optic atrophy, and deafness (a nuclear gene that predisposes to multiple mitochondrial DNA deletions in families with Wolfram syndrome [MIM 222300]). Among all, the only disease with clinical similarities to the novel disorder described here is, of course, Huntington disease.

There are multiple brain-related ESTs with no known disease association in the linkage interval (between markers D4S2366 and D4S2983). Although ~200 genes are expected to map within this interval, only three known genes have been mapped in the 4p15.3 region. These are: quinone dihydropteridine reductase (*QDPR*; Brown and Dahl 1987), pristanoyl acyl-coenzyme A oxidase 3 (*ACOX3*; Vanhooren et al. 1997), and do-

Table 2

Homozygosity Multipoint Linkage Analysis for the Disease Locus and Markers D4S431 and D4S394 Spanning a 3-cM Region at 4p15.3 with GeneHunter

Marker	Distance (KcM)	Maximum LOD
D4S2366	.00	3.03
D4S431	2.00	4.71
	2.62	4.71
	3.24	4.71
	3.86	4.71
	4.48	4.71
D4S394	5.09	4.71
D4S2983	7.09	3.03

pamine receptor D5 (*DRD5*; Eubanks et al. 1992). *QDPR* was excluded as a candidate, since defects in the gene cause phenylketonuria through dihydropteridine reductase deficiency in affected individuals (Smooker et al. 1995).

The *ACOX3* gene product (pristanoyl-CoA oxidase) plays a role in desaturation of 2-methyl branched-chain fatty acids and the bile-acid intermediates di- and tri-hydroxycoprostanic acids. The gene is expressed to such a low extent in liver that its mRNA cannot be detected by Northern-blot analysis (Vanhooren et al. 1996), and its product is undetected by immunoblotting or by enzyme-activity measurements (Van Veldhoven et al. 1994). Screening the *ACOX3* gene for sequence alterations in patients with elevated pristanic-acid levels (affected by generalized peroxisomal disorders) did not identify any mutations (R. J. A. Wanders, personal communication). Thus, the *ACOX3* gene is an unlikely candidate but cannot be entirely excluded.

The human D5 dopamine receptor (*DRD5* [MIM 126453]) stimulates biphasic intracellular accumulation of cAMP (adenylate-cyclase activity) (Grandy et al. 1991). Sherrington et al. (1993) cloned the *DRD5* receptor and used it to map the *DRD5* gene by linkage studies in 39 Centre d'Études du Polymorphisme Humain (CEPH) pedigrees to 4p15.3. Tissue in situ hybridization studies have shown that *DRD5* is neuron specific and localizes in limbic regions of the brain. Beischlag et al. (1995) determined that *DRD5* mRNA is most abundant in discrete cortical areas (layers II, IV, and VI), the dentate gyrus, and hippocampal subfields but is expressed at very low levels in the striatum. In addition, *DRD5* mRNA antisense riboprobes label discrete cell bodies in the *pars compacta* of the *substantia nigra*.

DRD5 was initially considered a likely candidate gene because it maps in the linkage interval, and alterations in the various subtypes of dopamine receptors have been

associated with chorea, dystonia, and rigidity (Wichmann and DeLong 1997)—all part of the clinical presentation of this novel Huntington-like syndrome. The five affected individuals were genotyped for a *DRD5* intragenic dinucleotide repeat, and all were heterozygous. Because homozygosity by descent at the affected locus is expected, heterozygosity renders *DRD5* a less likely candidate. Heterozygosity at *DRD5* defines the proximal boundary of the linkage interval. *DRD5* can not be excluded as a candidate on the basis of heterozygosity for the intragenic dinucleotide repeat if an autosomal dominant pattern of inheritance for this disorder is to be considered. The high rate of affected siblings (50%) in the sibship is consistent with autosomal dominant inheritance. Because it was impossible to confirm the presence of the disease in the affected cousins by clinical examination, there could be a slight chance that the disease is inherited as an autosomal dominant trait associated with germline mosaicism in one of the parents. In that case, *DRD5* would remain a likely candidate gene. However, the inferred haplotypes of the unaffected individuals (fig. 1) do not support this concept.

At present, cloning of the gene cannot be attempted, because of the size of the linkage interval (6–7 cM) and the small number of affected individuals (five). Identification of additional affected families would allow narrowing of the linkage interval, which, in turn, might facilitate physical mapping for identification and cloning of the offending gene. It is possible that some of the Huntington-like cases described by Andrew et al. (1994) (which had no expansion in the Huntington CAG repeat, but in which linkage to the distal 4p region could not be excluded) represent additional patients with this novel disease.

The similarity in clinical symptomatology of this novel disease and HD may indicate a common pathogenesis. The identification of the defective gene and its product causing this novel disorder promises to elucidate the molecular mechanism underlying this particular basal-ganglia neurodegenerative disease and, potentially, others. In summary, the inheritance pattern and unique localization to 4p15.3 for this Huntington-like disease are consistent with the identification of a novel, autosomal recessive neurodegenerative disorder.

Acknowledgments

The authors would like to thank Dr. James Gusella (Massachusetts General Hospital, Harvard School of Medicine) for his advice in selecting markers in the 4p region for the high-density mapping of this Huntington-like disorder, Mr. Mohamed Al-Hamed for technical assistance, Mr. Islam Butt for synthesizing all primers used in this study, Dr. Malcolm Pat-

erson for his critical review of this manuscript, and the Research Center's administration for their support.

Electronic-Database Information

Accession numbers and URLs for data in this article are as follows:

Online Mendelian Inheritance in Man (OMIM), <http://www.ncbi.nlm.nih.gov/Omim> (for JHD [143100], Huntington-disease-like neurodegenerative disorder [603218], Wolframs syndrome [222300], and *DRD5* [126453])

References

- Andrew SE, Goldberg YP, Kremer B, Squitieri F, Theilmann J, Zeisler J, Telenius, H, et al (1994) Huntington disease without CAG expansion: phenocopies or errors in assignment? *Am J Hum Genet* 54:852–863
- Beischlag TV, Marchese A, Meador-Woodruff JH, Damask SP, O'Dowd BF, Tyndale RF, van Tol HHM, et al (1995) The human dopamine D5 receptor gene: cloning and characterization of the 5'-flanking and promoter region. *Biochemistry* 34:5960–5970
- Bates GP, MacDonald ME, Baxendale S, Youngman S, Lin C, Whaley WL, Wasmuth JJ, et al (1991) Defined physical limits of the Huntington disease gene candidate region. *Am J Hum Genet* 49:7–16
- Bond CE, Hodes ME (1996) Direct amplification of the CAG repeat of Huntington without amplification of CCG. *Clin Chem* 42:773–774
- Brown RM, Dahl HH (1987) Localization of the human dihydropteridine reductase gene to band p15.3 of chromosome 4 by in situ hybridization. *Genomics* 1:67–70
- Eubanks JH, Altherr M, Wagner-McPherson C, McPherson JD, Wasmuth JJ, Evans GA (1992) Localization of the D5 dopamine receptor gene to human chromosome 4p15.1-p15.3, centromeric to the Huntington's disease locus. *Genomics* 12:510–516
- Farrer LA, Conneally PM (1985) A genetic model for age at onset in Huntington disease. *Am J Hum Genet* 37:350–357
- Grandy DK, Zhang Y, Bouvier C, Zhou QY, Johnson RA, Allen L, Buck K, et al (1991) Multiple human D5 dopamine receptor genes: a functional receptor and two pseudogenes. *Proc Nat Acad Sci USA* 88:9175–9179
- Kendall TL, Ryerley DJ, Dearn R (1991) Isolation of DNA from blood. *Anal Biochem* 195:74–76
- Kruglyak L, Daly MJ, Lander ES (1995) Rapid multipoint linkage analysis of recessive traits in nuclear families, including homozygosity mapping. *Am J Hum Genet* 56:519–527
- Kruglyak L, Daly MJ, Reeve-Daly MP, Lander ES (1996) Parametric and nonparametric linkage analysis: a unified multipoint approach. *Am J Hum Genet* 58:1347–1363
- Sherrington R, Mankoo B, Attwood J, Kalsi G, Curtis D, Buetow K, Povey S, et al (1993) Cloning of the human dopamine D5 receptor gene and identification of a highly polymorphic microsatellite for the *DRD5* locus that shows tight linkage to the chromosome 4p reference marker RAF1P1. *Genomics* 18:423–425

- Smooker PM, Christodoulou J, McInnes RR, Cotton RG (1995) A mutation causing DHPR deficiency results in a frameshift and a secondary splicing defect. *J Med Genet* 32:220–223
- van Dijk JG, van der Velde EA, Roos RA, Bruyn GW (1986) Juvenile Huntington disease. *Hum Genet* 73:235–239
- van Veldhoven PP, van Rompuy P, Fransen M, de Bethune B, Mannaerts GP (1994) Large-scale purification and further characterization of rat pristanoyl-CoA oxidase. *Eur J Biochem* 222:795–801
- Vanhooren JC, Fransen M, de Bethune B, Baumgart E, Baes M, Torrekens S, van Leuven F, et al (1996) Rat pristanoyl-CoA oxidase: cDNA cloning and recognition of its C-terminal (SQL) by the peroxisomal-targeting signal 1 receptor. *Eur J Biochem* 239:302–309
- Wichmann T, DeLong M (1997) Physiology of the basal ganglia and pathophysiology of movement disorders of basal ganglia origins. In: Watts RL, Kollen WL (eds) *Movement disorders: neurologic principles and practice*. McGraw Hill, New York, pp 73–95
- Xiang F, Almqvist EW, Huq M, Lundin A, Hayden MR, Edstrom L, Anvret M, et al (1998) A Huntington disease-like neurodegenerative disorder maps to chromosome 20p. *Am J Hum Genet* 63:1431–1438